

Features

The SE™ mounting consists of an annular rubber section, securely bonded to a single steel support plate. A clearance hole is provided which can either be left plain or tapped to suit the application.

As the rubber element is in direct contact with the supporting surface, friction is normally sufficient to prevent the suspended equipment from “walking”.



Novibra® type SE™

Type SE™ is suitable for the isolation of high frequency disturbances and provides reduction of structure-borne noise.

Specific applications are:

- ▼ Office equipment
- ▼ Textile machinery
- ▼ Domestic appliances
- ▼ Electric motors
- ▼ Weighing equipment

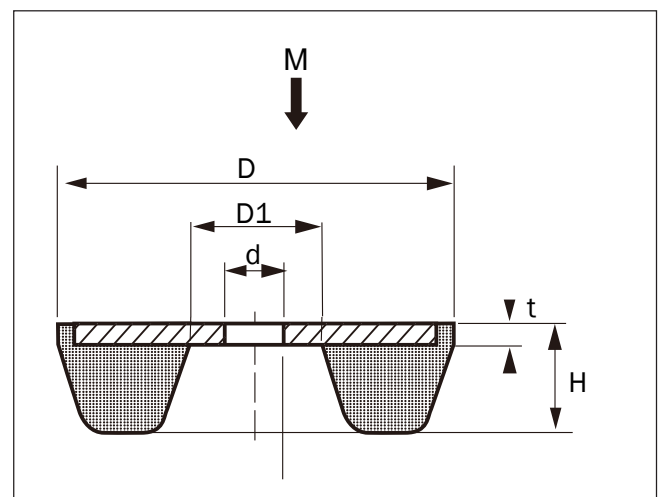
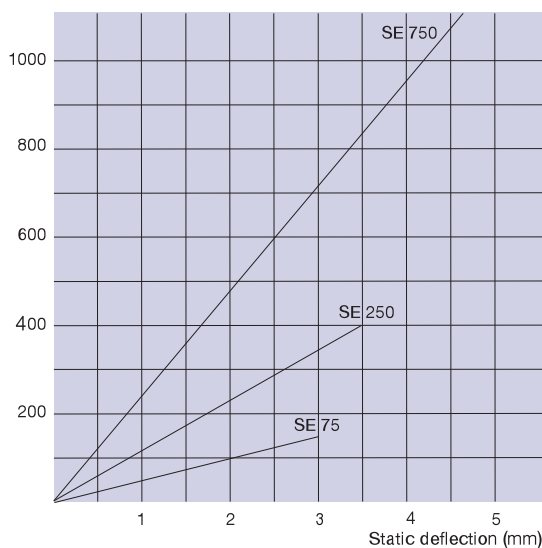

Type	Drawing no.	Part no. 50°IRH	Dimensions in mm					M-Max (Kg) 50°IRH	Weight (Kg)
			D	D1	d	H	t		
SE 75	19-0563	20-00612	55	18	8	15	3	150	0,069
SE 250	19-0728	20-00631	75	25	10	17	4	400	0,172
SE 750	19-0729	20-00632	115	40	14	24	4	1100	0,456