

ANB™



Features

Buffer type ANB consists of a cylindrical rubber body bonded to a square baseplate of steel. Each corner of the baseplate has a fixing hole.

Special high-hysteresis rubber compound is used to ensure as much energy absorption as possible. The volume of the rubber is used at optimum efficiency.

For new machine developments simpler designs and lighter calculated forces can be considered enabling a lower cost.

Novibra® type ANB™

The shock buffer type ANB is used to effectively limit movement of equipment or machine components.

Typical field applications would be:

- ▼ Wagons
- ▼ Cabinets
- ▼ Falling goods
- ▼ Lifting cranes
- ▼ Off-road material handling equipment
- ▼ Container handling equipment
- ▼ Forestry vehicles
- ▼ Traversing cranes
- ▼ Working beams

Through the damping of the rubber a high degree of energy absorption is achieved. The rubber is stiffer under dynamic conditions compared to static or pseudo static loading; hence more energy is absorbed for a given deformation. Diagram 4 shows the effect of the energy factor.

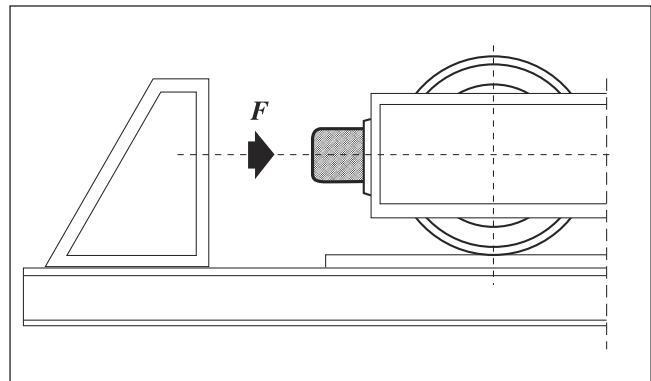

Fig. 1. Traverse crane with shock buffer ANB.

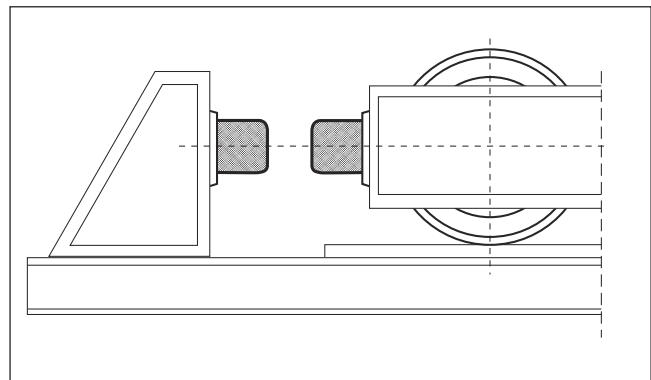

Fig. 2. Traverse crane with 2 ANB buffers connected in series..

Type	Drawing no.	Part no.	Dimensions in mm						Weight (Kg)	F-Max (N)
			K	A	D	d	H	t		
ANB50	15-4034	10-00151	70	50	50	7	43	3	0.2	8000
ANB75	15-4035	10-00152	100	75	75	9	63	3	0.5	20000
ANB100	15-4037	10-00153	130	100	100	11	84	4	1.2	41000
ANB150	15-4032	10-00010	185	150	150	13.5	126	6	3.9	90000
ANB200	15-4033	10-00011	240	200	200	13.5	168	8	9.1	180000

For calculation purposes the following equations can be used:

$$E = \frac{m \cdot v^2}{2} \quad (1)$$

$$E = F \cdot s \quad (2)$$

$$F = m \cdot a \quad (3)$$

$$s = \frac{a \cdot t^2}{2} \quad (4)$$

$$v = \sqrt{a \cdot t} \quad (5)$$

$$v = \sqrt{2 \cdot a \cdot s} \quad (6)$$

$$v = \sqrt{2 \cdot g \cdot h} \quad (7) \text{ applicable in free fall}$$

E = energy in Nm

m = mass in kg

v = velocity in m/s

F = force in N

s = distance in m

a = acceleration in m/s²

t = time in s

g = acceleration due to gravity 9.81 m/s²

h = height in m

d = spring travel in m

Equation (4)- (7) valid for initial velocity = 0

ANB 50
ANB 75

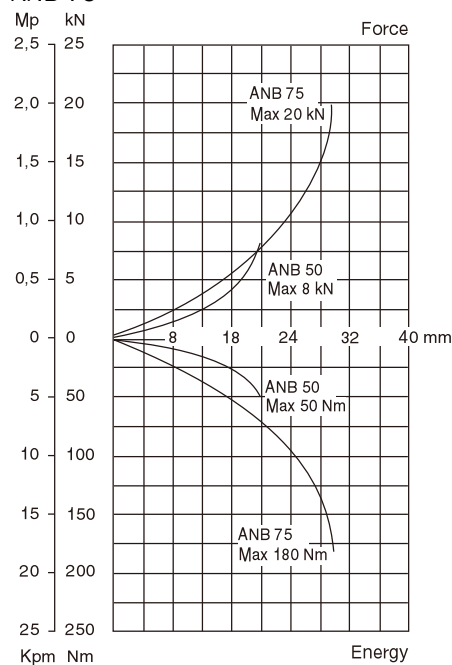

Diagram 1

ANB 100
ANB 150

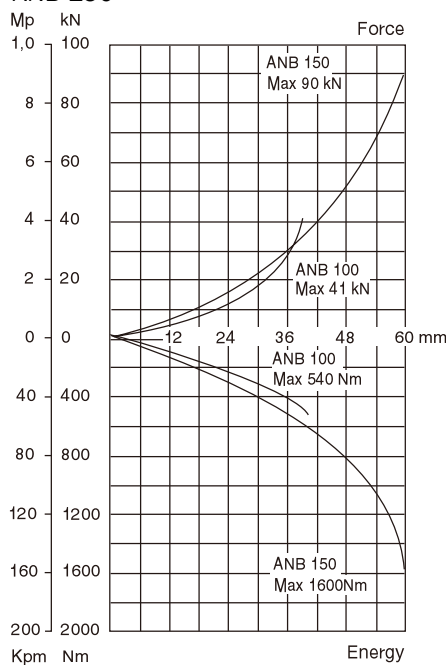

Diagram 2

ANB 200

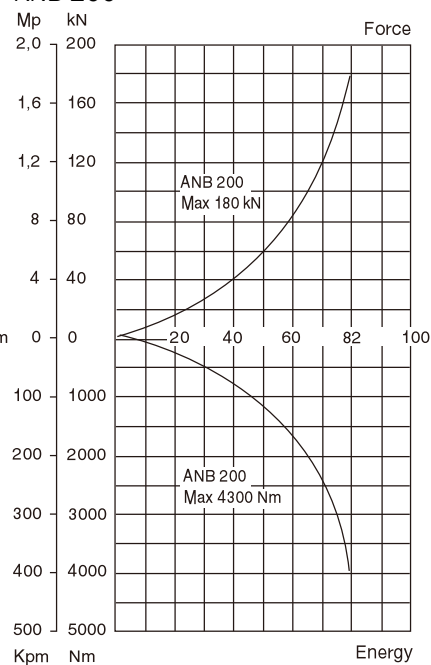
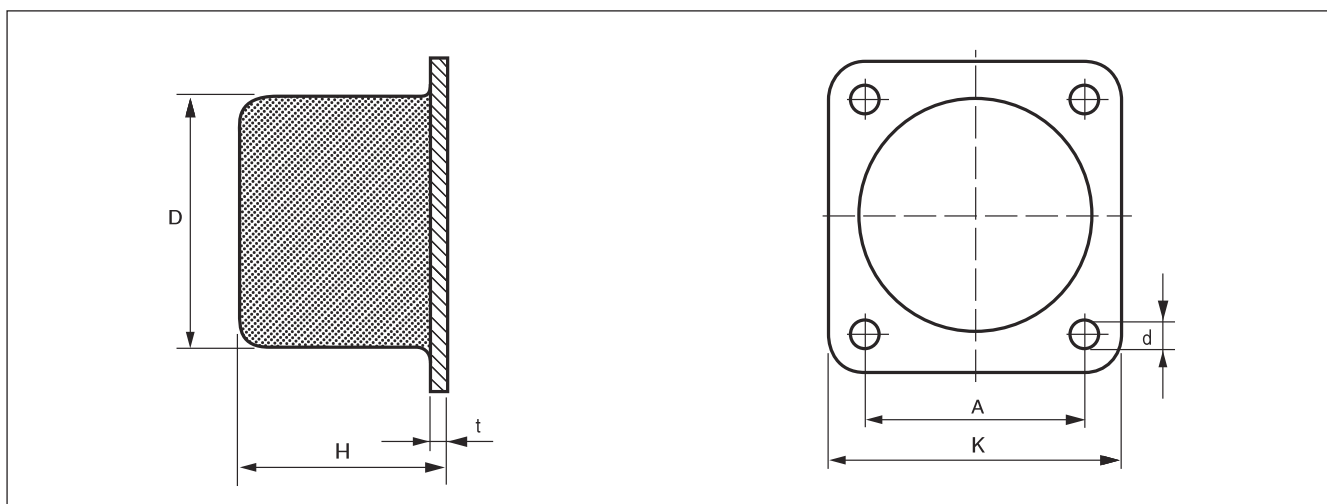

Diagram 3



ANB™

CALCULATION EXAMPLES

The figures in parenthesis refer to the equations.

EXAMPLE 1: FREE FALL CALCULATION

1850 kg weight is to be dropped 1.83 metres onto 4 ANB buffers. What size ANB should be used? What force will be transmitted to the floor?

$$\text{Energy } E = F \cdot s \text{ (2)} = 1850 \cdot 9.81 \cdot 1.83 = 33212 \text{ Nm}$$

$$\text{Velocity at impact (shock velocity) } v = \sqrt{2 \cdot g \cdot h \text{ (7)}} = \sqrt{2 \cdot 9.81 \cdot 1.83} = 6 \text{ m/s.}$$

REFER TO ENERGY FACTOR GRAPH

If 50% deformation is allowed, the energy factor at 6 m/s is 0.4. Then dynamic energy 33212 Nm corresponds to $33212 \cdot 0.4 = 13285$ Nm static energy and for 4 buffers the static energy per buffer is 3320 Nm.

REFER TO FORCE-ENERGY DIAGRAM

Select ANB 200 which can each absorb up to 4300 Nm at 80 mm compression (which is 50% of static height) or will compress 76 mm at 3320 Nm.

$$\begin{aligned} \text{Force at impact surface} \\ &= \text{force at 76 mm deflection} / 0.4 \\ &= 150 / 0.4 = 375 \text{ kN per buffer} \\ &= 1500 \text{ kN for 4 buffers} \end{aligned}$$

Hence if 1850 kg is dropped 1.83 metres onto 4 x ANB 200 buffers they will each compress 76 mm and the total force on the floor will be 1500 kN.

EXAMPLE 2A: CRANE BUFFER CALCULATION

A crane weighs 2000 kg and travels at 1.6 m/s. What size ANB buffers should be used to stop it and what will the final force be?

The dynamic or kinetic energy

$$E = \frac{m \cdot v^2}{2} = \frac{2000 \cdot 1.6^2}{2} = 2560 \text{ Nm (1)}$$

REFER TO ENERGY FACTOR GRAPH

Assuming a 50% deformation, the energy factor = 0.75 at 1.6 m/s. Hence the equivalent static energy is $2560 \cdot 0.75 = 1920$ Nm. Then for 2 buffers the static energy is 960 Nm per buffer.

REFER TO FORCE-ENERGY DIAGRAM

ANB 150 buffers can be chosen with a deflection at 960 Nm of 49 mm, which is only 41% of a free height of 120 mm, whereas 50% had been assumed. With the energy factor reduced to 0.72 (for 41% deflection at 1.6 m/s) the static energy is:

$$2560 / 2 \times 0.72 = 922 \text{ Nm}$$

Shock velocity m/s

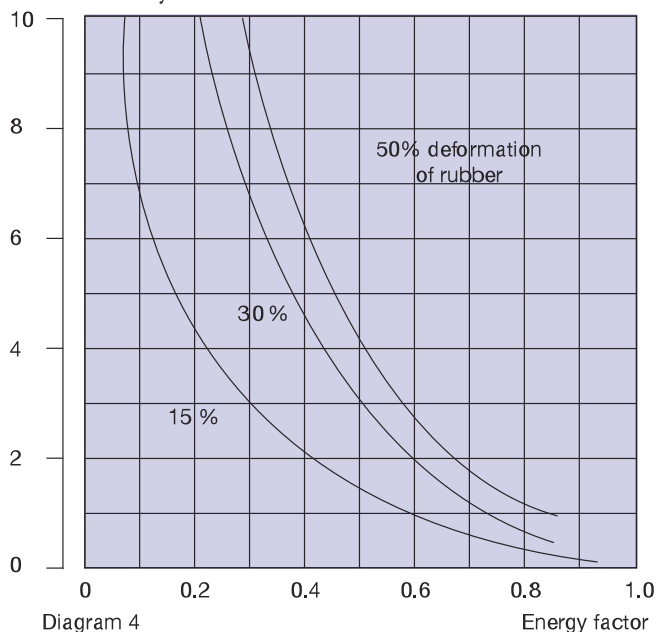

REFER TO FORCE-ENERGY DIAGRAM FOR ANB 150

At 922 Nm static energy, the deflection is 48.5 mm (close to 49 mm). Then the static force at 48.5 mm deflection is about 51 kN. Therefore the dynamic load (Force at impact) = $51 / 0.72 = 71$ kN. Hence 2 x ANB 150 buffers will deflect 48.5 mm and transmit a force of 71 kN or 7240 kg each, i.e. the structure must withstand 14.6 tons.

EXAMPLE 2B: CRANE BUFFER CALCULATION

How can the dynamic force calculated in example 2a be reduced, and by how much?

The force will be reduced and the deflection will be increased if ANB 150 buffers are connected in series (i.e. 4 buffers instead of 2) as illustrated by fig. 2.

Then, assuming 30% deformation the energy factor at 1.6 m/s = 0.68.

Hence the equivalent static energy is $2560 \cdot 0.68 = 1740$ Nm and for 4 buffers the static energy is 435 Nm per buffer.

The force-Energy diagram shows that at 435 Nm, buffer ANB 150 deforms 35 mm. This corresponds to 29.2% of a free height of 120 mm which is close to assumed value 30%.

Then the static force at 35 mm deflection is 26 kN and the dynamic load at impact will be:

$$26 / 0.68 = 38 \text{ kN}$$

Hence 4 x ANB 150 buffers connected 2 + 2 will give a total deflection of 70 mm with a final force per double arrangement of 38 kN or 3870 kg, i.e. the structure must withstand 7.7 tons.