

# SIM™



## Novibra® type SIM™

Type SIM™ is used for vibration isolation of small to medium sized machines:

- ▼ Fans
- ▼ Pumps
- ▼ Engines
- ▼ Compressors
- ▼ Measurement equipment
- ▼ Marine propulsion engines
- ▼ Refrigeration and air-conditioning

## Features

SIM™ is a mounting for mobile applications. The strong metal parts and the soft vertical stiffness combined with high stiffness in the longitudinal direction makes it suitable for suspension of marine engines both with and without thrust bearing.

Its unique construction and the latest production methods make Novibra type SIM a high performance mounting having a number of advantages.

- ▼ Low vertical natural frequency 8-9 Hz combined with high longitudinal stiffness, ratio approx  $k_l/k_v=3.5-5.5$ .
- ▼ Special designed stronger bottom plate and top cover to withstand high shock loads from tough mobile applications.
- ▼ Load range from 50-580kg.
- ▼ Fitted as standard with a shock proof device (up to 5g) with resilient stop.
- ▼ Corrosion protected to cope with arduous environments with treatment Fe/Zn8C as per ISO 2081.
- ▼ SIM can be delivered with two types of height adjusters, one standard type HA and HAD for higher load requirements.
- ▼ Clear and durable product marking. Mountings can be identified after several years in operation.
- ▼ Domed shape top cover to protect against oil contamination.

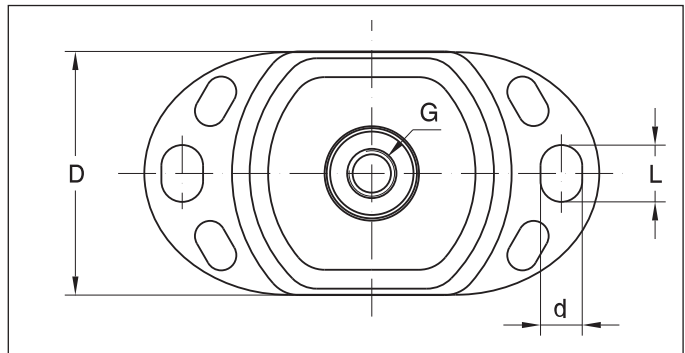
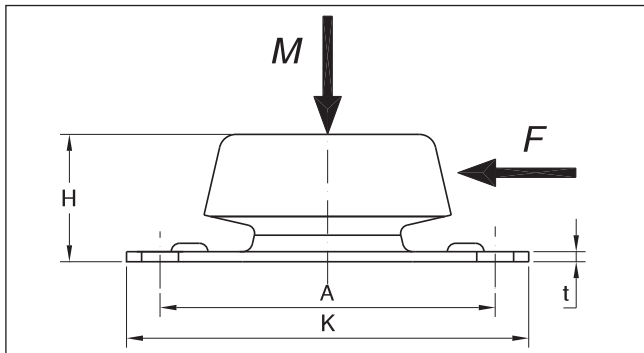

| Type    | IRH     | Part no. | Dimensions in mm |     |     |    |    |    |   | Max Load M ((Kg) | Max Longitudinal Force F(N) | Weight (Kg) |      |
|---------|---------|----------|------------------|-----|-----|----|----|----|---|------------------|-----------------------------|-------------|------|
|         |         |          | D                | A   | K   | H  | d  | L  | t |                  |                             |             |      |
| SIM 100 | 40° IRH | 10-00043 | 64               | 100 | 120 | 38 | 11 | 15 | 3 | M12              | 50                          | 750         | 0,35 |
|         | 50° IRH | 10-00046 | 64               | 100 | 120 | 38 | 11 | 15 | 3 | M12              | 60                          | 1000        | 0,35 |
|         | 60° IRH | 10-00044 | 64               | 100 | 120 | 38 | 11 | 15 | 3 | M12              | 100                         | 1400        | 0,35 |
|         | 70° IRH | 10-00045 | 64               | 100 | 120 | 38 | 11 | 15 | 3 | M12              | 130                         | 2000        | 0,35 |
| SIM 200 | 40° IRH | 10-00047 | 75               | 140 | 175 | 50 | 13 | 20 | 4 | M16              | 100                         | 2000        | 0,75 |
|         | 50° IRH | 10-00050 | 75               | 140 | 175 | 50 | 13 | 20 | 4 | M16              | 150                         | 3000        | 0,75 |
|         | 60° IRH | 10-00048 | 75               | 140 | 175 | 50 | 13 | 20 | 4 | M16              | 230                         | 4500        | 0,75 |
|         | 70° IRH | 10-00049 | 75               | 140 | 175 | 50 | 13 | 20 | 4 | M16              | 310                         | 6000        | 0,75 |
| SIM 300 | 40° IRH | 10-00051 | 112              | 182 | 216 | 70 | 18 | 26 | 5 | M20              | 220                         | 5000        | 2,03 |
|         | 50° IRH | 10-00054 | 112              | 182 | 216 | 70 | 18 | 26 | 5 | M20              | 300                         | 6500        | 2,03 |
|         | 60° IRH | 10-00052 | 112              | 182 | 216 | 70 | 18 | 26 | 5 | M20              | 460                         | 9000        | 2,03 |
|         | 70° IRH | 10-00053 | 112              | 182 | 216 | 70 | 18 | 26 | 5 | M20              | 580                         | 12000       | 2,03 |

Note: The natural frequencies and degrees of isolation are based on dynamic characteristics of the mountings.

Load per mounting (kg)

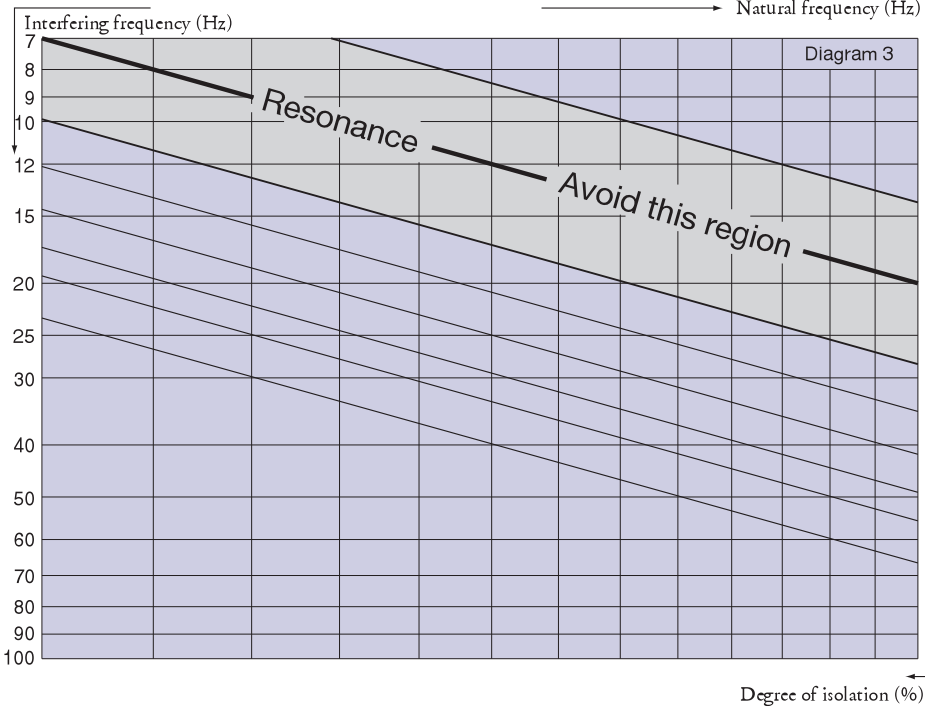
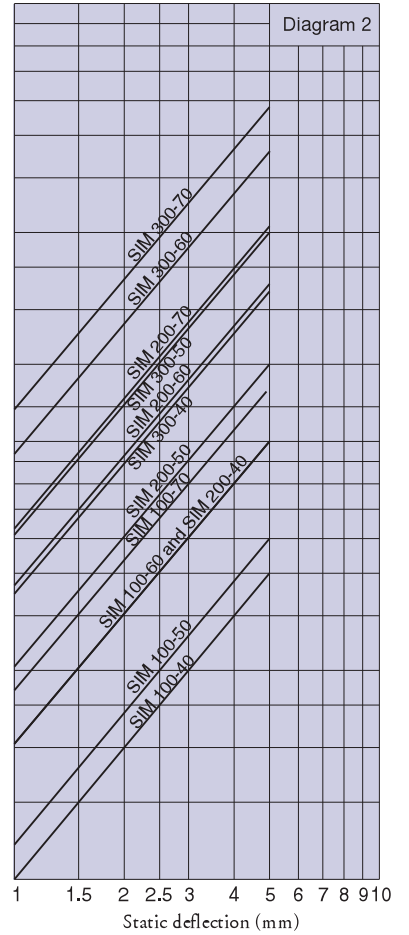
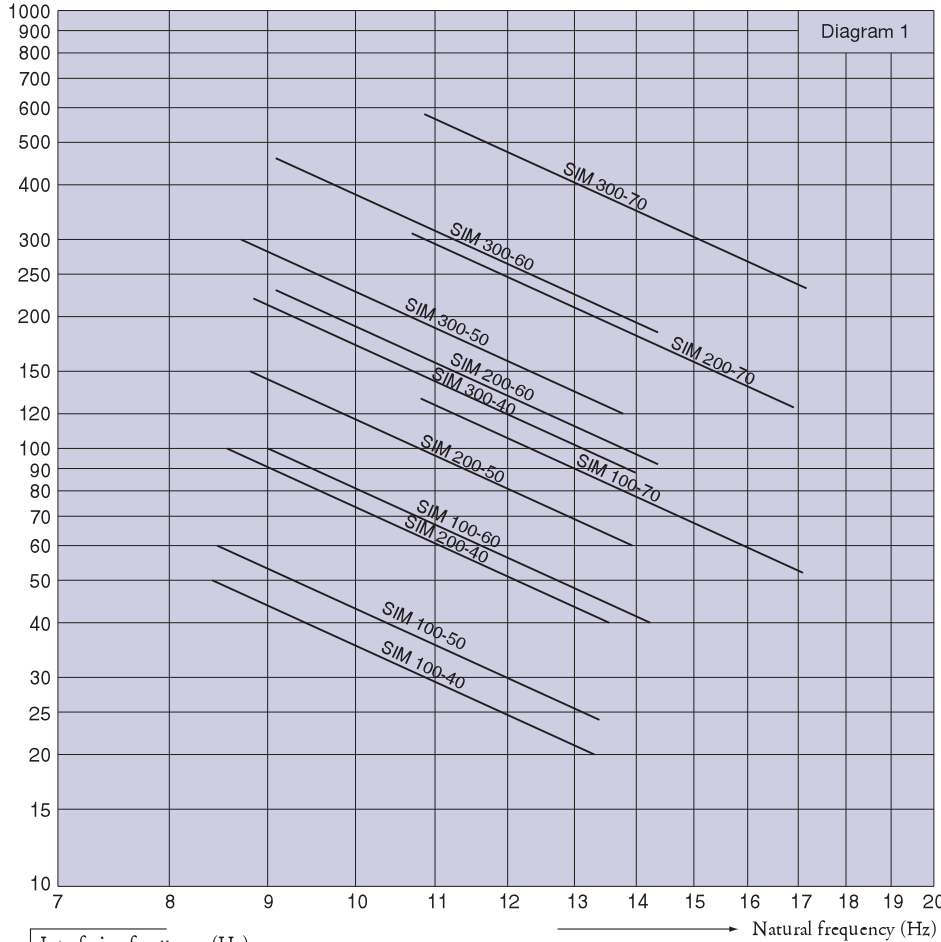

To select correct mounting, following data are needed:

- 1) Load per mounting (kg)
- 2) Interfering frequency (Hz)  
(Hz = rpm / 60)

Select correct load line in diagram 1 and correct interference line in diagram 3.

The load line intersects with required type of mounting.

Connect this intersection point vertically down to the interference line in diagram 3. Here, on the sloping curve, the isolation degree is indicated.

For static deflection, see diagram 2.

